



Pathfinder™ Heavy Duty Rotating Light

Twin Sealed Beams

100SB Series



Edwards 100SB Series Pathfinder Rotating Beacons have powerful dual sealed beam lamps that rotate 360 degrees within a high impact polycarbonate dome. Polycarbonate domes are safer and easier to clean than glass domes and allow the transmission of more light than heavily colored glass. Polycarbonate domes are also ideal for applications such as those required in food processing plants that prohibit the use of glass.

The Edwards 100SB Series also features a PVC coated base that allows for greater corrosion resistance and durability than plastic or simple stamped metal bases. Wiring is routed through the 3/4" NPT hub on the bottom of the unit. The Pathfinder is conduit mounted. Available in five lens colors: red, amber, blue, green, and clear.

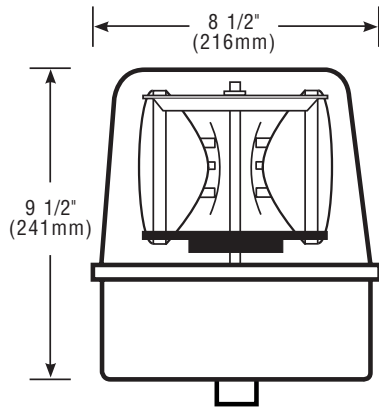

FEATURES

- > Twin sealed beams
- > Quiet Belt drive for simplified maintenance
- > PVC coated base
- > "Search light" beam effect

SPECIFICATIONS

- > Two PAR36 / 35,000 candlepower bulbs
- > 80 flashes per minute
- > 900 hour long lamp life

AGENCY APPROVALS

- > UL 1638 Listed
- > cUL Listed
- > NEMA Type 3R

Cat. No.	Dome Color	Replacement Dome	Electrical Rating	Flash Rate	Replacement Lamp	Replacement Belt	Peak Candlepower
100SBR-N5	Red	100SB-LR	120V 60 Hz	80 FPM	GE #4416-1	100SB-RB	35,000
100SBA-N5	Amber	100SB-LA	0.8 Amp				
100SBB-N5	Blue	100SB-LB					
100SBG-N5	Green	100SB-LG					
100SBC-N5	Clear	100SB-LC					